

Gamma scintillation detector with a Si-PM array and ARDUINO Due processor

Madalina Cruceru¹, Andra Udrescu¹, V. Lupusoru¹, L.N. Cojocariu^{1,2}, C.C. Radulescu¹, V.M. Placinta¹

¹Horia Hulubei National Institute for R&D in Physics and Nuclear Engineering, PO BOX MG-6, Bucharest –Magurele, Romania

²Faculty of Physics, University of Bucharest, Magurele, Romania

Abstract: 2x2 Si-PM NUV-MT silicon photomultiplier array from Broadcom with an area size of 8x8mm² in connection with an Arduino Due processor and an YAG:Ce(from China, Hangzhou Yong Hee Photonics Co., Ltd) 18x18x10mm³ inorganic scintillator crystal is ensambled. This detector system is used for gamma-ray spectroscopy with different applications in nuclear physics(high energy physics and medical imaging). It was obtained an energy resolution of 8.0 % at the energy 661keV of Cs137. This value is better than the energy resolution of 12.0% obtained for 661 keV of Cs137 with the same volume YAG:Ce crystal and a PIN photodiode readout, type S3204-08(from Hamamatsu, Japan). Three different radioactive sources are used to test this readout system: Na22, Ba133 and Cs137.

I. METHODOLOGY: was ensambled a detector with YAG:Ce crystal with 18x18x10 mm³ and a Si-PM array from Broadcom. The setup is presented:

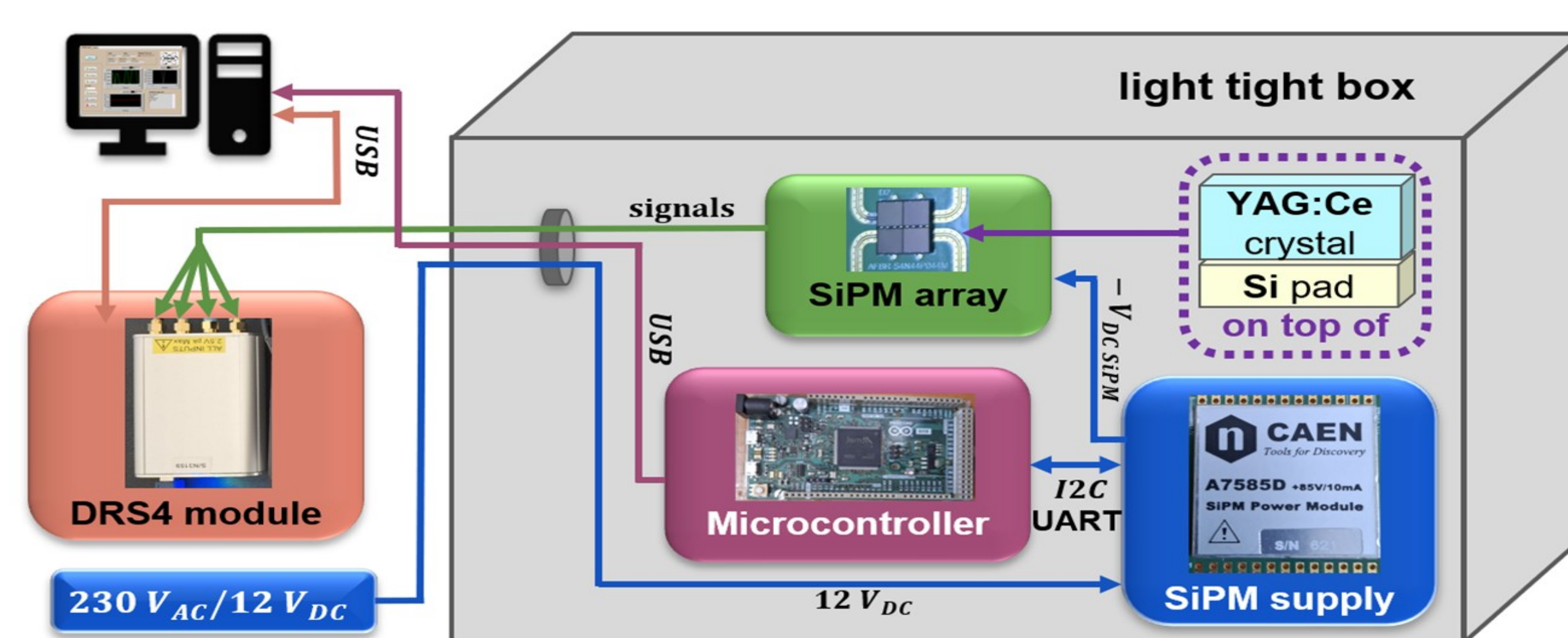
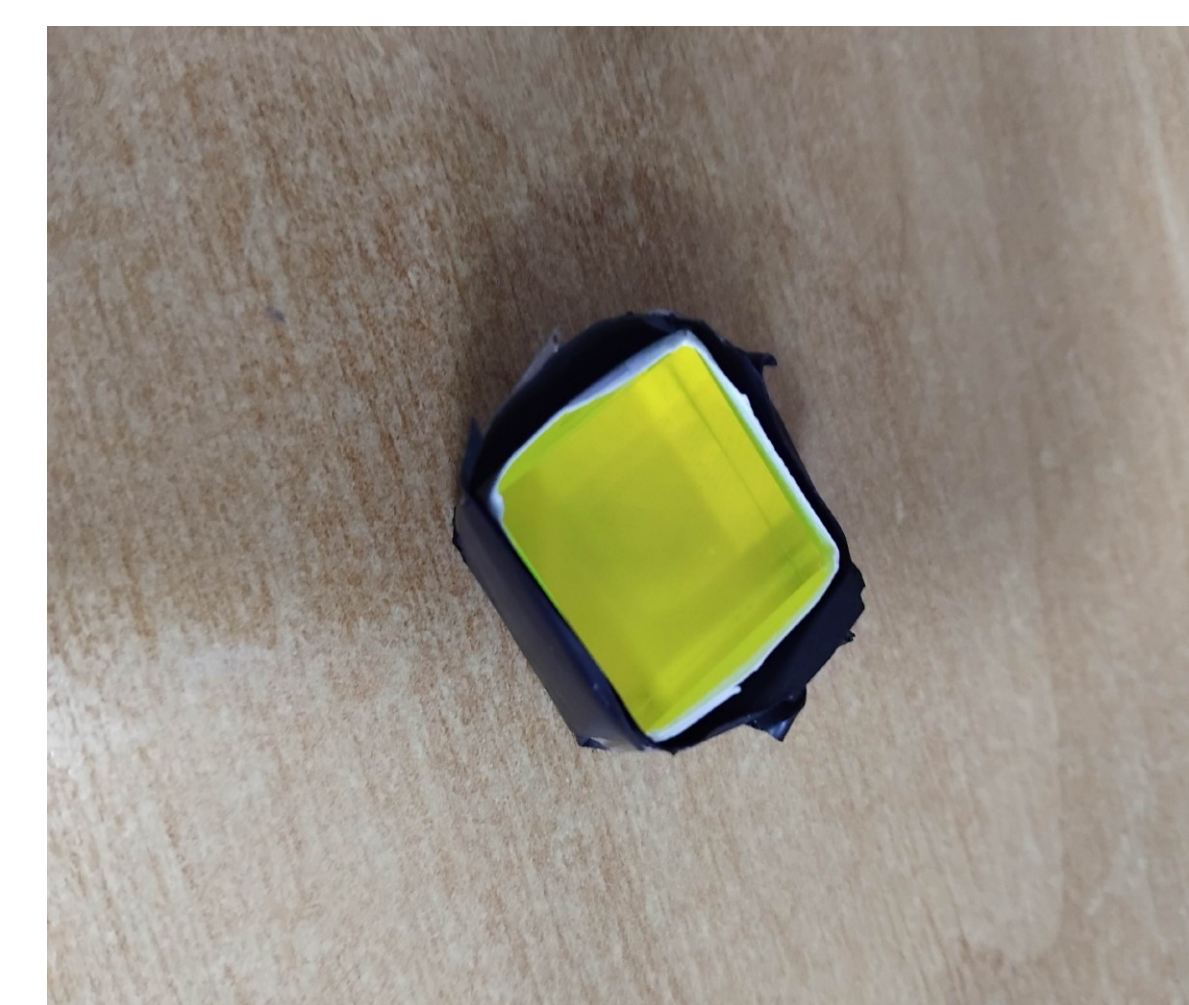

Fig.1.The description of the detector setup.



II. RESULTS: gamma spectrum for Cs-137 with 8% energy resolution at the 661keV energy .

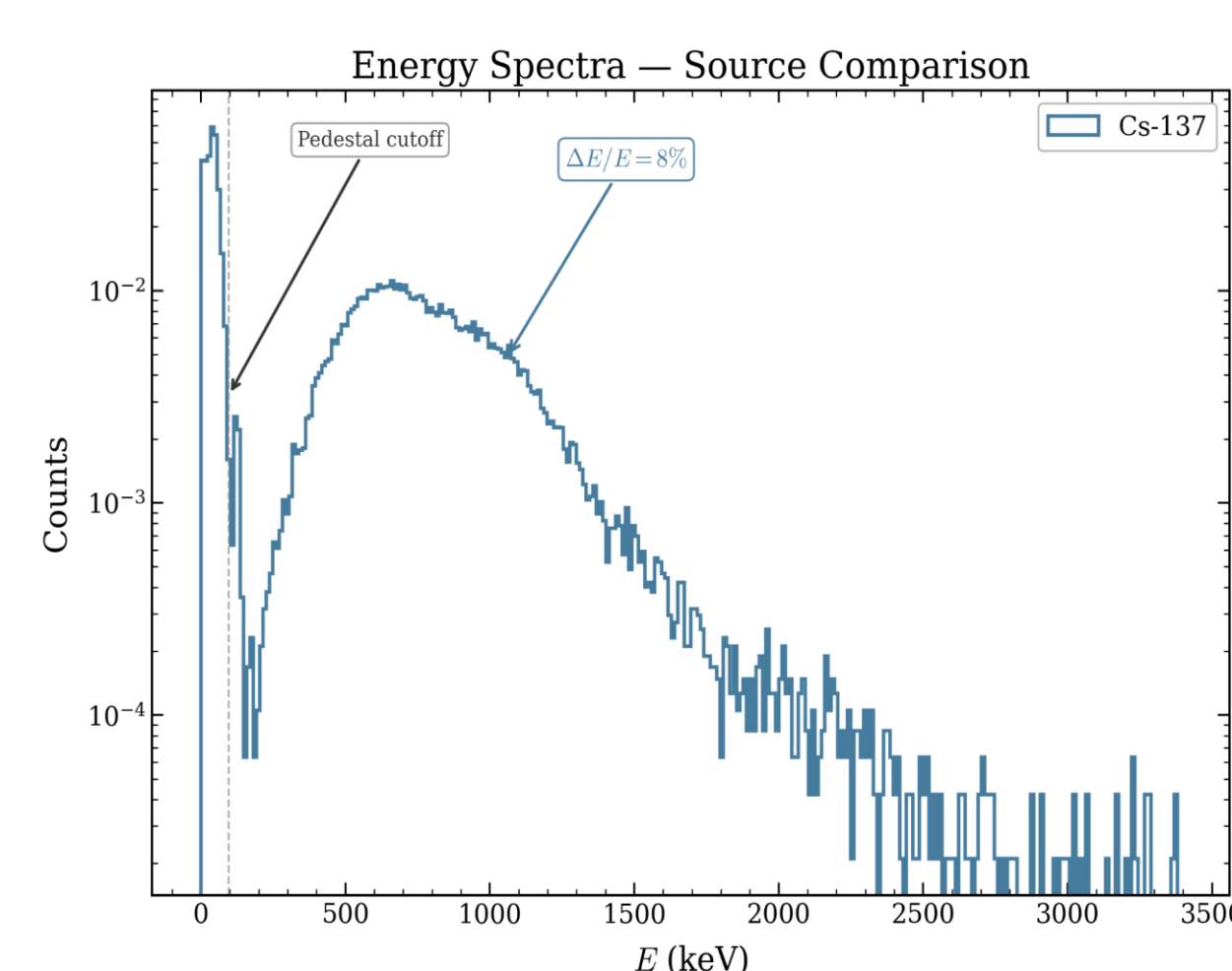

Fig.4. Gamma spectrum of the Cs-137 obtained with the above setup.

Fig.2.The photo of the detector setup. Fig.3.The YAG;Ce crystal in a black paper and Tyvek.

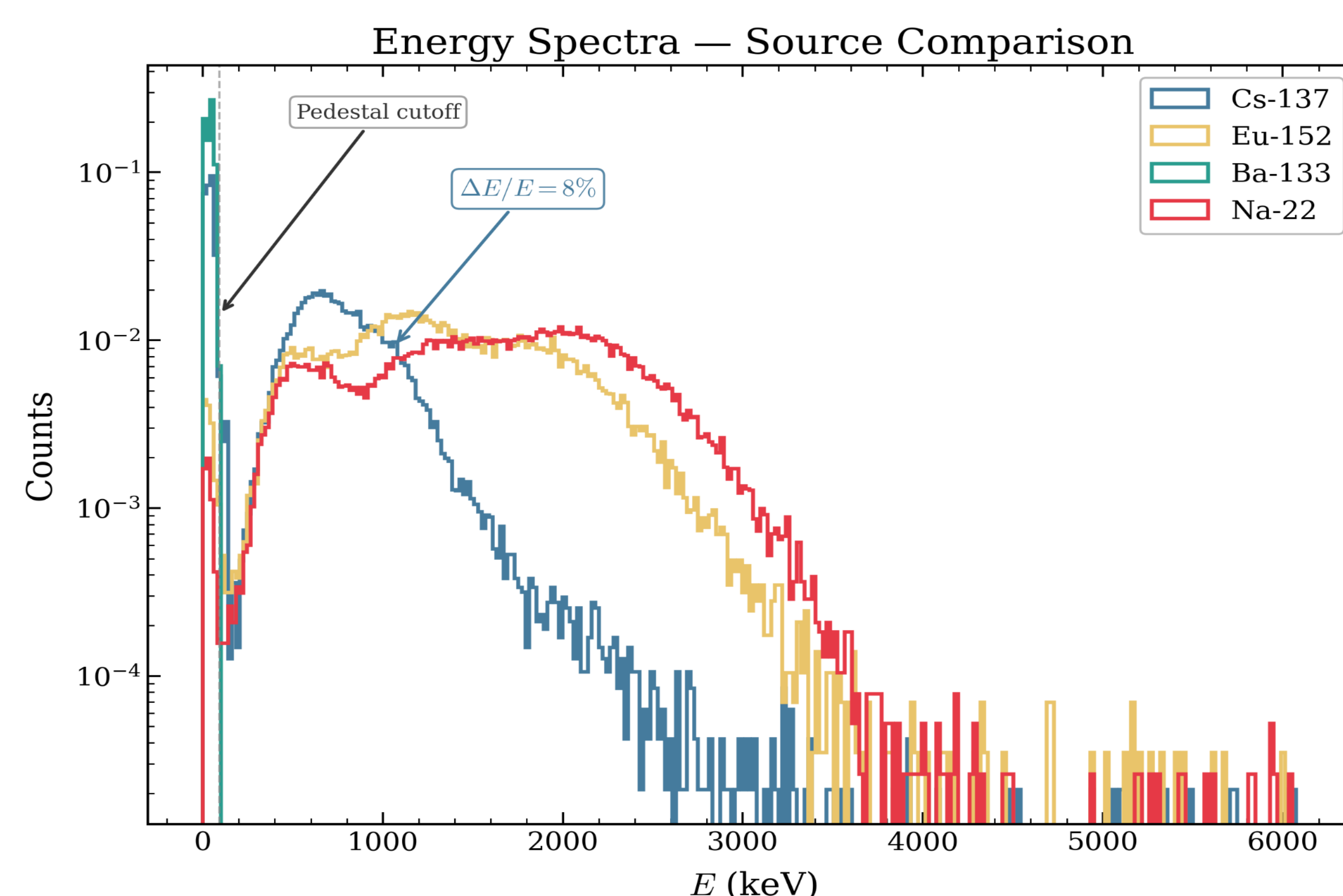

Fig.5. Four gamma spectra of Cs-137, Eu-152, Ba-133 and Na-22 are obtained in the same conditions and same setup with YAG:Ce.

III. CONCLUSIONS: with YAG:Ce crystal and a Si-PM we obtained gamma spectra for few radioactive sources: Cs-137, Ba-133, Eu-152 and Na-22. The cost of the setup is low(around 500Eur) in comparison with other detectors setups.

Acknowledgements: The research leading to these results has received funding from the Romanian Ministry of Research, Innovation and Digitization through the Project PN 23210104 / 2025 and through the grant 9/25.11.2024 of the Institute of Atomic Physics Bucharest (IFA).